

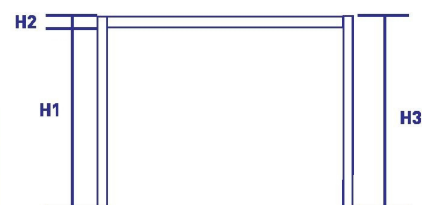

linea dama

## DAMA 19 PLUS



**TABELLA ALTEZZE**

MISURE (cm)	H1 (cm)	H2 (cm)	H3 (cm)
standard	235	16	251

**TABELLA PESI**

MISURE (cm)	PESO (KG)
300X350	400
300X400	425
300X440	445
351X350	425
351X400	455
351X440	480
402X350	455
402X400	485
402X440	510
453X350	505
453X400	515
453X440	545
504X350	510
504X400	545
504X440	580
555X350	535
555X400	575
555X440	610
606X350	565
606X400	605
606X440	645

### Caratteristiche

- Struttura in alluminio verniciato
- Tettoia orientabile con lamelle in alluminio rotanti da 0° a 140°
- Movimentazione motorizzata con radiocomando di serie.
- Gronda integrata con scarico acqua nei piantoni.
- Possibilità di attacco a parete.
- Possibilità di accoppiamento sulla larghezza e sulla sporgenza.
- Possibilità di applicazione led bianchi o RGB integrati all'interno delle travi perimetrali.
- Colore verniciatura standard: Bianco 9010. Altri colori a preventivo (possibilità colore verniciatura lame diverso dalla struttura)

### Dimensioni

- Altezza sotto trave standard: 235 cm
- Altezza max sotto trave: 300 cm
- Larghezza max per singolo modulo: 440 cm
- Sporgenza max per singolo modulo: 606 cm
- Larghezza lama: 19 cm
- Passo lame: 17 cm

linea dama



## profili utilizzati

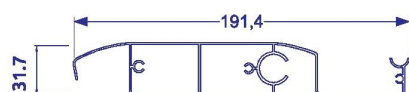

lamella



compensatore

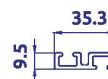

astina di movimentazione

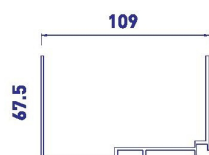

gronda

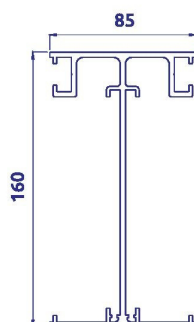

trave



cartellina di copertura

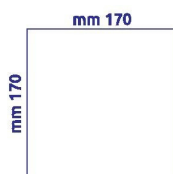

piantone

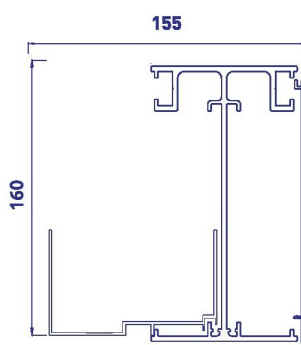

trave perimetrale  
assemblata

## accessori

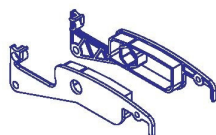

tappi lamella

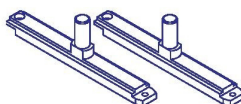

scivoli per lame

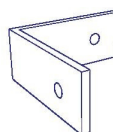

staffa ad elle

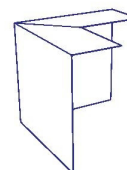

carter  
angolare



## struttura singola

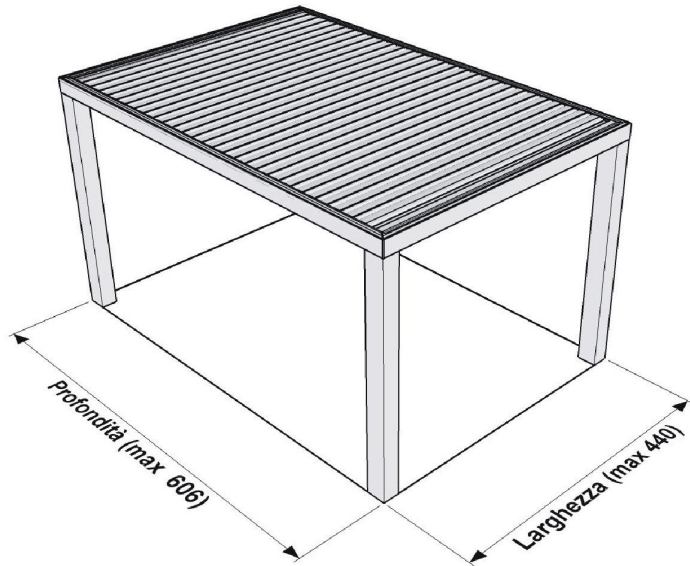

## struttura autoportante

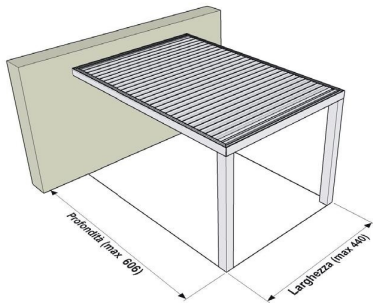

struttura singola addossata a parete  
su lato larghezza

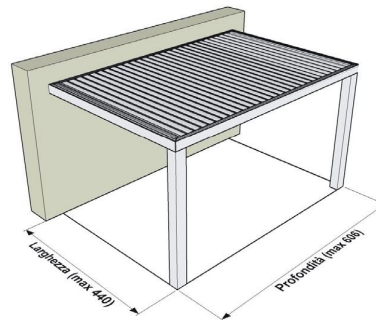

struttura singola addossata a parete  
su lato profondità



linea dama

## struttura accoppiata

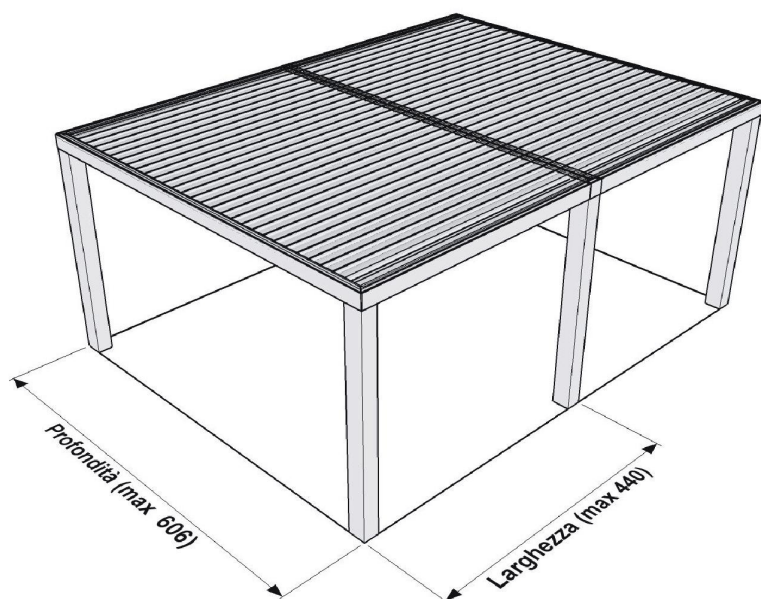

## struttura accoppiata su lato profondità

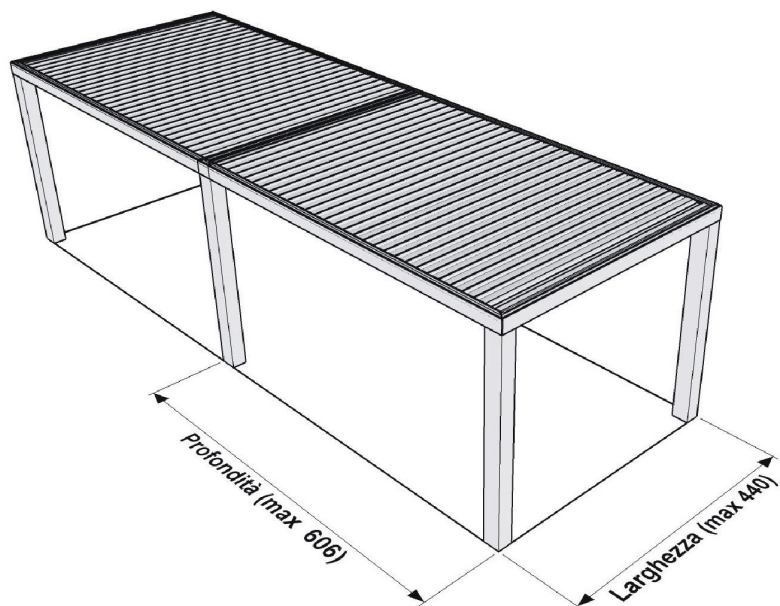

## struttura accoppiata su lato larghezza